



Codes		
E1104I-T40ASU	E1104I-50ASU	E1104I-T80ASU
E1106I-T40ASU	E1106I-T50ASU	E1106I-T80ASU
E1107I-T40ASU	E1107I-T50ASU	E1107I-T80ASU

Fegen Solar Modules SM series are All-in-One, Plug & Play, Outdoor, Scalable enclosures that incorporate all solar thermal and solar electric distribution gear for buildings in one device.

- No need of a conventional indoor boiler room
- No on-site labor cost
- Immediate start-up
- No responsibility conflicts
- Easy control and maintenance
- Scalable for infinite combinations

- **Tight double door dimensions**
- **40-80 gallons water storage**
- **Integrated heating element**
- **Robust AC pump design**
- **Solar back up system for redundancy**
- **Defrost system for reliability**
- **Solar pool gear option (P extension coded)**
- **Robust protected-ventilated 1ph 4-7WdC inverter**

CABIN GENERAL CHARACTERISTICS

	Thermal Part	Electrical Part
Type		RITTAL TS 8
External dimensions W x H x D (front view)	800 x 2000 x 800 mm 31,50 x 78,74 x 31,50 inch	400 x 2000 x 800 mm 15,75 x 78,74 x 31,5 inch
Mounting plate W x H	699 x 1896 mm / 27,5 x 74,65 inches	699 x 1896 mm / 27,5 x 74,65 inches
Weight/pack	203 kg	124 kg
Material		Sheet steel
Cold / Hot Supply - Brass	1 ¼ inch	
Color		RAL 7035
Protection category IP to IEC 60 529		IP 55
Doors	1	1
Light		Auto door power On/Off - 600 lumens
Scalability		Unlimited
Protection		Over-temperature, Anti-freeze control
Approvals	Bureau Veritas, CSA, TÜV, DNV-GL, Lloyds Register of Shipping, Russian Maritime Register of Shipping, UL + C-UL	
Certificates	EAC,IK-Code, Protection category	
Declarations	Declaration of conformity, Manufacturer's declaration	

CABIN LIGHTING SYSTEM-TECHNICAL SPECIFICATIONS

General Data	
Type	RITTAL LED system light
Material	Light body: Extruded aluminium Light cover: Polycarbonate (halogen-free) Light ends: PC-ABS (halogen-free)
Color	Enclosure: RAL 7016
Protection category IP to IEC 60 529	IP 20
Dimensions	Width: 337 mm, Height: 55 mm, Depth: 23 mm
Rated operating voltage	100 V - 240 V, 1~, 50 Hz/60 Hz
Operating temperature	Operation (environment): -20°C...+55°C
Power consumption	7 W
Luminous flux	600 lm
Light colour	4000 K (neutral white)
Protection category	II (all-insulated)
Weight/pack	0.35 kg
Approvals	CCC, ENEC
Certificates	EAC

VENTILATION - TECHNICAL SPECIFICATIONS

	Fan	Thermostat
Type	RITTAL TopTherm	RITTAL internal thermostat
Color	RAL 7035	RAL 7035
Protection category IP to IEC 60 529	IP 54 with standard filter and additional fine filter mat: IP 55 with standard filter and hose-proof hood: IP 56	
Protection category NEMA	with standard filter: Type 12 with standard filter and additional fine filter mat: Type 12 with standard filter and hose-proof hood: Type 3, 3R, 4, 4X	
Air throughput (unimpeded air flow):	At 50 Hz: 230 m ³ /h At 60 Hz: 250 m ³ /h	
Air throughput with outlet filter including standard filter mat (output 50/60 Hz)	203/230 m ³ /h	
Rated operating voltage:	115 V, 1~, 50 Hz/60 Hz	24 V - 230 V, 1~24 V - 60 V (DC)
Dimensions	Width: 255 mm Height: 255 mm	Width: 71 mm Height: 71 mm Depth: 33.5 mm
Build depth	25 mm	
Installation depth	107 mm	
Temperature range:	Bearing: -30°C...+70°C Operation (environment): -30°C...+55°C	Setting range: +5°C...+60°C
Power consumption	At 50 Hz: 40 W, At 60 Hz: 42 W	
Rated current (max.)	At 50 Hz: 0.52 A, At 60 Hz: 0.48 A	
Miniature circuit breaker/ fuse	4 A	
Noise level	At 50 Hz: 54 dB(A), At 60 Hz: 56 dB(A)	
Diagonal fan	Diagonal, self-starting shaded pole motor	
Weight/pack	2.26 kg	0.1 kg
Approvals	Approval overview CSA UL + C-UL - FTTA UR + C-UR	UL + C-UL VDE
Certificates	EAC	EAC
Declarations	Declaration of conformity	Declaration of conformity

SOLAR TANK CHARACTERISTICS

T40

T50

T60

General Data

Type	Sammler SV		
Solar tank capacity	160 lt / 40 gal	200 lt / 50 gal	300 lt / 80 gal
External dimensions W x H	580 x 1058 mm 22,83 x 41,6 inch	580 x 1292 mm 22,83 x 50,9 inch	580 x 1735 mm 22,83 x 68,3 inch
Weight	67 kg / 235 lb	82 kg / 235 lb	107 kg / 235 lb
Number of boilers	1		
Max pressure primary circuit	3 bar		
Max pressure secondary circuit	3 bar		
Electric Resistance	1.50 – 4.00 KW (UL Ready) - not included		
Anti-corrosion protection	2 x magnesium anodes		
Certification	SRCC, Solar Keymark, CE		

SOLAR PUMP STATION

General Data

Type	Caleffi 279 series		
Dimensions	Height (with controller extension): 381 mm Width (with insulation) : 203,2 mm		
Suitable fluids	water, glycol solution		
Max. percentage of glycol	50%		
Maximum working temperature	air separator side supply: 320°F (160°C), pump side return: 230°F (110°C)		
Max. working pressure	145 psi (10 bar)		
Safety relief valve working temperature range	-20 to 320°F (-30–160°C)		
Safety relief valve setting	90 psi (6 bar)		
Check valve min. opening pressure (Dp)	1/4 psi (2 kPa)		
Shut-off and check valves working temperature range	-20 to 320°F (-30–160°C)		
Flow meter working temperature range	15 to 230°F (-10–110°C)		
Flow rate adjustment range	2 to 8 gpm		
Flow rate indicator accuracy	±10%		
Pressure gauge scale	0 to 145 psi (0–10 bar)		
Temperature gauge scale	32 to 320°F (0–160°C)		
Connections	3/4" female straight thread		
Hose connection	3/4"		
Fill/drain connections	with hose connection 9/16" OD (15 mm)		

Materials

Shut-off valve body	Brass
Check valve	Brass
Temperature gauge	steel/aluminum
Air Separator body	Brass
Instrument holder fitting body	Brass
Instrument holder fitting sealing gaskets	EPDM
Instrument holder fitting O-Ring seal elements	EPDM
Flow meter body	Brass
Flow meter transparent level gauge	PS
Flow meter flow indicator	Brass
Insulation material	PP
Insulation average thickness	20 mm
Insulation density	45 kg/m3
Insulation working temperature	-5...120°C
Insulation thermal conductivity	0.263 BTU·in/hr·ft ² ·°F 0.037 W/(m·K) at 50°F (10°C)
Insulation reaction to fire (UL94)	class HBF

CONTROLLER

General Data	
Type	Caleffi iSolar
Dimensions	Width: 171.45 mm, Height: 111.1 mm, Depth: 50.8 mm
Weight	0.4 kg
Housing	PC-ABS
Protection type	Indoor
Display	LCD
Interface	Three soft push buttons
Inputs	4 temperature sensors
Outputs	1 or 2 triac or standard relays
Switching Capacities	1 A - 115 VAC
Power Supply	12V - 24V
Power Consumption	1W, 1.5VA
Data Connection	V-Bus
Performance	
ΔT adjustment range	2-40° ΔT (1-20 °K)
Min. temperature differential	2° ΔT (1 °K)
Hysteresis	2° $\Delta T \pm 1^\circ \Delta T$ (1 °K $\pm 5^\circ \Delta T$)
Max. tank temperature range	210 - 375 °F (100 - 190 °C)
Emergency shut down of the collector	230 - 395 °F (110 - 200 °C)
Min. collector temperature option	50 - 195 0F (10 - 90 °C)
Antifreeze temperature option	15 - 50 °F (-10 - 10 °C)
kWh (BTU) flow input	0 - 5 gpm (0 - 20 lpm)
Agency approvals	cTUVus
Temperature Sensors	
Platinum RTD type	1,000 ohm
Collector sensor working range	-58 - 355 °F (-50 - 180 °C)
Tank sensor working range	15 - 175 °F (-10 - 80 °C)
Length of collector black cable	60 in (1.5 m)
Length of tank sensor gray cable	95 in (2.5 m)
Glycol (recommended type)	
Type	DOWFROST HD
Recommended temperature range	-46°C...163°C
Freezing Point	-33.5 °C
Boiling Point @ 1 bar	105.6 °C
Freeze protection temperature	-51 °C
Burst protection temperature	-73 °C
Weight % Propylene Glycol	94
Weight % performance additives	6
Specific gravity (15 °C)	1.053 - 1.062
pH of Solution	9.5 - 10.5
Reserve alkalinity	15.0 ml

TECHNICAL DATA AND TYPES

Fimer type code	UNO-DM-3.3-TL-PLUS-US-Q	UNO-DM-4.6-TL-PLUS-US-Q	UNO-DM-5.0-TL-PLUS-US-Q
General specifications			
Rated grid AC voltage (V_{acr})	208 V 240 V	208 V 240 V	208 V 240 V
Nameplate Apparent Power (S_{max})	3300 VA 3300 VA	4600 VA 4600 VA	5000 VA 5000 VA
Nameplate Output Active Power (P_{max} @ $\cos\phi=1$)	3300 W 3300 W	4600 W 4600 W	5000 W 5000 W
P_{RATED} : Output Active Power @ V_{acr} and $\cos\phi=\pm 0,9$	2700 W 3000 W	3780 W 4140 W	4118 W 4500 W
Input side (DC)			
Number of independent MPPT channels		2	
Maximum usable power for each channel	2000 W	3000 W	3500 W
Absolute maximum voltage (V_{max})	600 V	600 V	600 V
Start-up voltage (V_{start})	200 V (Adj. 120-350)	200 V (Adj. 120-350)	200 V (Adj. 120-350)
Full power MPPT voltage range with parallel MPPT configuration at P_{acr}	160-530 V 170-530 V	140-530 V 150 - 530 V	155-480 V 170-480 V
Operating MPPT voltage range	$0.7*V_{start}$ - 580 V (≥ 90)	$0.7*V_{start}$ - 580 V (≥ 90)	$0.7*V_{start}$ - 580 V (≥ 90)
Maximum usable current per channel	10 A	16 A	19 (CH1) - 11.5 (CH2)
Maximum current (I_{dmax})	20 A	32 A	30,5 A
Maximum short circuit current per channel		25 A	
Number of wire landing terminals	2 pairs, capable of connecting two parallel strings		
Array wiring termination	Terminal block, pressure clamp, AWG20-8		
Output side			
Grid connection type	1 Φ /2W Split- Φ /3W	1 Φ /2W Split- Φ /3W	1 Φ /2W Split- Φ /3W
Adjustable voltage range (V_{min} - V_{max})	183-228 V 211-264 V	183-228 V 211-264 V	183-228 V 211-264 V
Grid frequency	60 Hz	60 Hz	60 Hz
Adjustable grid frequency range	50-64 Hz	50-64 Hz	50-64 Hz
Maximum current ($I_{ac,max}$)	14,5 A	20 A	22 A
Power factor	>0.995, adj. +/-0.8	>0.995, adj. +/-0.8	>0.995, adj. +/-0.8
Total harmonic distortion at rated power	<2%	<2%	<2%
Contributory fault current	16 A	22 A	24 A
Grid wiring termination type	Terminal block, pressure clamp, AWG20-6		
Input protections			
Reverse polarity protection	Yes, from limited current source		
Over-voltage protection type	Varistor		
PV array ground fault detection	Pre start-up RISO and dynamic GFDI		
Output protections			
Anti-islanding protection	Meets UL1741 / IEEE1547 requirements		
Over-voltage protection type	Varistor, 2 (L1 - L2 / L1 - G)		
Maximum AC OCPD rating	20 A	25 A	30 A
Efficiency			
Maximum efficiency	97%	97%	97.4%
CEC efficiency	96.5% 96.5%	96.5% 96.5%	96.5% 97%
Operating performance			
Stand-by consumption	<8 W _{RMS}		
Nighttime consumption	<0.6 W _{RMS}		
Auxiliary Output			
Isolated Auxiliary Power Supply ¹⁾	24 Vdc, 0.4 A max		

TECHNICAL DATA AND TYPES

Fimer Type code **UNO-DM-3.3-TL-PLUS-US-Q** **UNO-DM-4.6-TL-PLUS-US-Q** **UNO-DM-5.0-TL-PLUS-US-Q**

Embedded communication	
Embedded communication interface	Wireless ²⁾
Embedded communication protocol	ModBus TCP (SunSpec)
Commissioning tool	Web User Interface
Monitoring	Aurora Vision cloud (Plant Portfolio Manager, Plant Viewer, Energy Viewer)

Optional board UNO-DM-COM kit	
Optional communication interface	RS485 (use with meter for dynamic feed-in control), Alarm/Load manager relay, Remote ON/OFF
Optional communication protocol	ModBus RTU (SunSpec), Aurora Protocol
Advanced functionalities provided	Dynamic feed-in control, Load manager relay

Optional board UNO-DM-PLUS Ethernet COM kit	
Optional communication interface	Ethernet, RS485, Alarm/Load manager relay, Remote ON/OFF
Optional communication protocol	ModBus TCP (SunSpec), ModBus RTU (SunSpec), Aurora Protocol

Environmental	
Ambient air operating temperature range	-25...+60°C / -13...140°F (derating above 50°C/122°F)
Relative humidity	0-100% RH condensing
Acoustic noise emission level	< 50 db (A) @1m
Maximum operating altitude without derating	6560ft (2000m)

Mechanical specifications	
Enclosure rating	Type 4X
Cooling	Natural convection
Dimension (H x W x D)	34 x 16.4 x 8.7 in (863 x 418 x 222 mm) ³⁾
Weight	35.3 lb (16 kg) ³⁾
Shipping weight	46lb (20,7kg) ³⁾
Mounting system	Wall bracket
Conduit connections	Bottom: Markings for (2) Concentric KOs 1", 3/4" and (2) KOs 1/2" Sides: Markings for Concentric KOs 1", 3/4" ³⁾
DC switch rating	600 V, 23 A @ 600 V, 38 A @ 500 V and 45 A @ 350 V

Safety	
Isolation level	Transformerless (floating array)
Safety and EMC standard	UL1741, IEEE1547.1, CSA-C22.2 N. 107.1-01, UL1998 UL 1699B-2018, FCC Part 15 Class B
Grid standard	IEC/EN 62109-1, IEC/EN 62109-2, AS/NZS 4777.2, EN 61000-6-1, EN 61000-6-2, EN 61000-6-3, EN 61000-6-4, EN 61000-3-11, EN 61000-3-12
Safety approval	CTUVUS

Available models	
Model with DC switch, wiring box, AFD, RSD supply output	UNO-DM-3.3-TL-PLUS-USSB-RA-Q UNO-DM-4.6-TL-PLUS-USSB-RA-Q UNO-DM-5.0-TL-PLUS-US-SBRA-QU

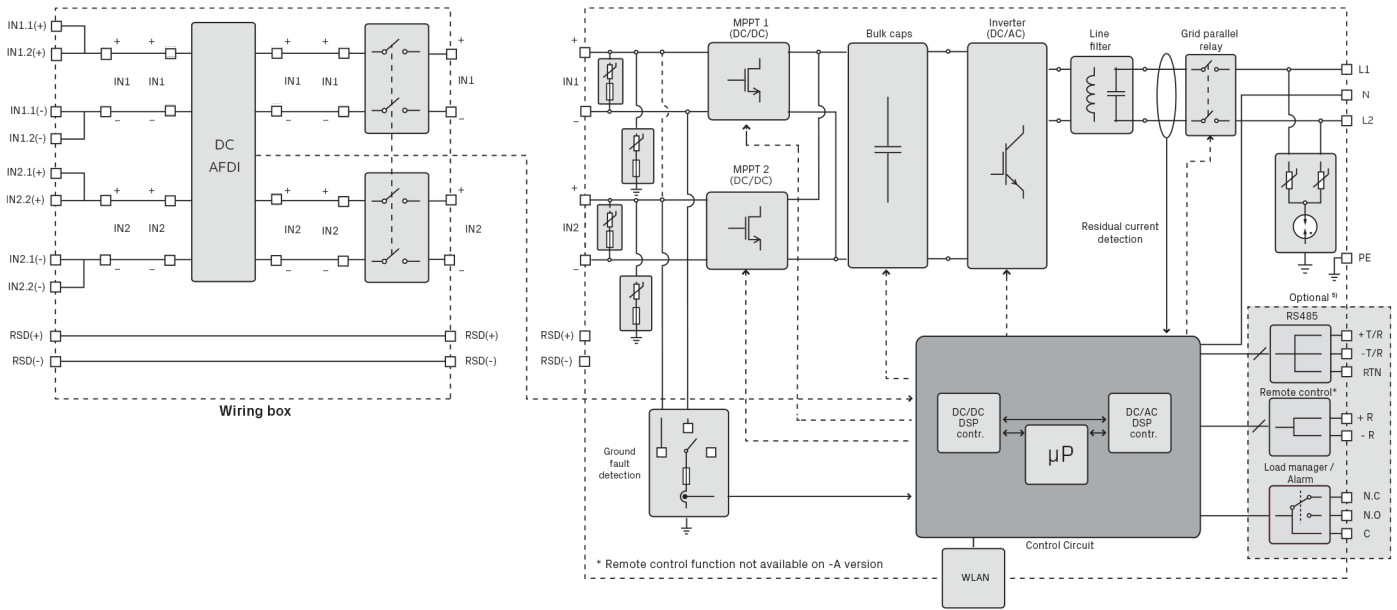

UNO-DM-4.0/4.6/5.0-TL-PLUS-Q string inverter block diagram

Models using other branded solar thermal or solar electric gear upon demand.