



Codes			
E11040-T160ASE	E11040-T200ASE	E11040-T300ASE	E11040-T500ASE
E11050-T160ASE	E11050-T200ASE	E11050-T300ASE	E11050-T500ASE
E11060-T160ASE	E11060-T200ASE	E11060-T300ASE	E11060-T500ASE

Fegen Solar Modules SM series are All-in-One, Plug & Play, Outdoor, Scalable enclosures that incorporate all solar thermal and solar electric distribution gear for buildings in one device.

- No need of a conventional indoor boiler room
- No on-site labor cost
- Immediate start-up
- No responsibility conflicts
- Easy control and maintenance
- Scalable for infinite combinations
- **Tight single door dimensions**
- **160-500 liters water storage**
- **Integrated heating element**
- **Robust AC pump design with controller**
- **Solar back up system for redundancy**
- **Defrost system for reliability**
- **Solar pool gear option (P extension coded)**
- **Cost efficient mounted outdoors 1ph 4-6kWdC inverter**

CABIN GENERAL CHARACTERISTICS

	Thermal Part
Type	RITTAL TS 8
External dimensions W x H x D (front view)	800 x 2000 x 800 mm / 31,50 x 78,74 x 31,50 inch
Mounting plate W x H	699 x 1896 mm / 27,5 x 74,65 inches
Weight/pack	124 kg
Material	Sheet steel
Cold / Hot Supply - Brass	1 ¼ inch
Color	RAL 7035
Protection category IP to IEC 60 529	IP 55
Doors	1
Light	Auto door power On/Off - 600 lumens
Scalability	Unlimited
Protection	Over-temperature, Anti-freeze control
Approvals	Bureau Veritas, CSA, TÜV, DNV-GL, Lloyds Register of Shipping, Russian Maritime Register of Shipping, UL + C-UL
Certificates	EAC,IK-Code, Protection category
Declarations	Declaration of conformity, Manufacturer's declaration
Certification	SRCC, Solar Keymark, CE

CABIN LIGHTING SYSTEM-TECHNICAL SPECIFICATIONS

	General Data
Type	RITTAL LED system light
Material	Light body: Extruded aluminium Light cover: Polycarbonate (halogen-free) Light ends: PC-ABS (halogen-free)
Color	Enclosure: RAL 7016
Protection category IP to IEC 60 529	IP 20
Dimensions	Width: 337 mm, Height: 55 mm, Depth: 23 mm
Rated operating voltage	100 V - 240 V, 1~, 50 Hz/60 Hz
Operating temperature	Operation (environment): -20°C...+55°C
Power consumption	7 W
Luminous flux	600 lm
Light colour	4000 K (neutral white)
Protection category	II (all-insulated)
Weight/pack	0.35 kg
Approvals	CCC, ENEC
Certificates	EAC

SOLAR TANK CHARACTERISTICS	T160	T200	T300	T500
General Data				
Type	Sammler SV			TESY EV
Solar tank capacity	160 lt / 40 gal	200 lt / 50 gal	300 lt / 80 gal	500 lt / 132 gal
External dimensions W x H	580 x 1058 mm 22,83 x 41,6 inch	580 x 1292 mm 22,83 x 50,9 inch	580 x 1735 mm 22,83 x 68,3 inch	750 x 1674 mm 29,5 x 66 inch
Weight	67 kg / 235 lb	82 kg / 235 lb	107 kg / 235 lb	145 kg / 320 lb
Number of boilers	1			
Max pressure primary circuit	3 bar			8 bar
Max pressure secondary circuit	3 bar			6 bar
Electric Resistance	1.50 – 4.00 KW (UL Ready) - not included			
Anti-corrosion protection	2 x magnesium anodes			
Certification	SRCC, Solar Keymark, CE			Solar Keymark, CE

SOLAR PUMP STATION

General Data	General Data
Type	Caleffi 279 series
Dimensions	Height (with controller extension): 381 mm Width (with insulation) : 203,2 mm
Suitable fluids	water, glycol solution
Max. percentage of glycol	50%
Maximum working temperature	air separator side supply: 320°F (160°C), pump side return: 230°F (110°C)
Max. working pressure	145 psi (10 bar)
Safety relief valve working temperature range	-20 to 320°F (-30–160°C)
Safety relief valve setting	90 psi (6 bar)
Check valve min. opening pressure (Dp)	1/4 psi (2 kPa)
Shut-off and check valves working temperature range	-20 to 320°F (-30–160°C)
Flow meter working temperature range	15 to 230°F (-10–110°C)
Flow rate adjustment range	2 to 8 gpm
Flow rate indicator accuracy	±10%
Pressure gauge scale	0 to 145 psi (0–10 bar)
Temperature gauge scale	32 to 320°F (0–160°C)
Connections	3/4" female straight thread
Hose connection	3/4"
Fill/drain connections	with hose connection 9/16" OD (15 mm)

	Materials
Shut-off valve body	Brass
Check valve	Brass
Temperature gauge	steel/aluminum
Air Separator body	Brass
Instrument holder fitting body	Brass
Instrument holder fitting sealing gaskets	EPDM
Instrument holder fitting O-Ring seal elements	EPDM
Flow meter body	Brass
Flow meter transparent level gauge	PS
Flow meter flow indicator	Brass
Insulation material	PP
Insulation average thickness	20 mm
Insulation density	45 kg/m3
Insulation working temperature	-5...120°C
Insulation thermal conductivity	0.263 BTU·in/hr·ft²·°F 0.037 W/(m·K) at 50°F (10°C)
Insulation reaction to fire (UL94)	class HBF

CONTROLLER

General Data	
Type	Caleffi iSolar
Dimensions	Width: 171.45 mm, Height: 111.1 mm, Depth: 50.8 mm
Weight	0.4 kg
Housing	PC-ABS
Protection type	Indoor
Display	LCD
Interface	Three soft push buttons
Inputs	4 temperature sensors
Outputs	1 or 2 triac or standard relays
Switching Capacities	1 A - 115 VAC
Power Supply	12V - 24V
Power Consumption	1W, 1.5VA
Data Connection	V-Bus
Performance	
ΔT adjustment range	2-40° ΔT (1-20 °K)
Min. temperature differential	2° ΔT (1 °K)
Hysteresis	2° $\Delta T \pm 1^\circ \Delta T$ (1 °K $\pm 5^\circ \Delta T$)
Max. tank temperature range	210 - 375 °F (100 - 190 °C)
Emergency shut down of the collector	230 - 395 °F (110 - 200 °C)
Min. collector temperature option	50 - 195 °F (10 - 90 °C)
Antifreeze temperature option	15 - 50 °F (-10 - 10 °C)
kWh (BTU) flow input	0 - 5 gpm (0 - 20 lpm)
Agency approvals	cTUVus
Temperature Sensors	
Platinum RTD type	1,000 ohm
Collector sensor working range	-58 - 355 °F (-50 - 180 °C)
Tank sensor working range	15 - 175 °F (-10 - 80 °C)
Length of collector black cable	60 in (1.5 m)
Length of tank sensor gray cable	95 in (2.5 m)
Glycol (recommended type)	
Type	DOWFROST HD
Recommended temperature range	-46°C...163°C
Freezing Point	-33.5 °C
Boiling Point @ 1 bar	105.6 °C
Freeze protection temperature	-51 °C
Burst protection temperature	-73 °C
Weight % Propylene Glycol	94
Weight % performance additives	6
Specific gravity (15 °C)	1.053 - 1.062
pH of Solution	9.5 - 10.5
Reserve alkalinity	15.0 ml

TECHNICAL DATA AND TYPES

Fimer type code	UNO-DM-4.0-TL-PLUS-Q	UNO-DM-4.6-TL-PLUS-Q	UNO-DM-5.0-TL-PLUS-Q
Input side			
Absolute maximum DC input voltage ($V_{max,abs}$)	600 V		
Start-up DC input voltage (V_{start})	200 V (adj. 120...350 V)		
Operating DC input voltage range ($V_{dcr,min} \dots V_{dcr,max}$)	0.7 x Vstart...580 V (min 90 V)		
Rated DC input voltage (V_{dcr})	360 V		
Rated DC input power (P_{dcr})	4250 W	4750 W	5150 W
Number of independent MPPT	2		
Maximum DC input power for each MPPT ($P_{MPPT,max}$)	3000 W	3000 W	3500 W
DC input voltage range with parallel configuration of MPPT at P_{acr}	130...530 V	150...530 V	170...480 V
DC power limitation with parallel configuration of MPPT	Linear derating from Max to Null [530V≤VMPPT≤580V]	Linear derating from Max to Null [530V≤VMPPT≤580V]	Linear derating from Max to Null [480V≤VMPPT≤580V]
DC power limitation for each MPPT with independent configuration of MPPT at P_{acr} max unbalance example	3000 W [190 V≤VMPPT≤530 V] the other channel: P _{dcr} -3000 W [90 V≤VMPPT≤530 V]	3000 W [190 V≤VMPPT≤530 V] the other channel: P _{dcr} -3000 W [90 V≤VMPPT≤530 V]	On MPPT 1: 3500 W [185 V≤VMPPT≤480 V] On MPPT 2: P _{dcr} -3500 W [145 V≤VMPPT≤480 V] or 3500 W (305 V≤VMPPT≤480 V) with no power on MPPT1
Maximum DC input current ($I_{dcr,max}$) / for each MPPT ($I_{MPPT,max}$)	32.0/16.0 A	32.0/16.0 A	30.5/19-11.5 A (MPPT 1 - MPPT 2)
Maximum input short circuit current for each MPPT	20.0 A	20.0 A	22.0 A
Number of DC input pairs for each MPPT	1		
DC connection type ¹⁾	Quick Fit PV Connector		
Input protection			
Reverse polarity protection	Yes, from limited current source		
Input over voltage protection for each MPPT-varistor	Yes		
Photovoltaic array isolation control	According to local standard		
DC switch rating for each MPPT (version with DC switch)	25 A / 600 V		
Output side			
AC grid connection type	Single-phase		
Rated AC power (P_{acr} @cosφ=1)	4000 W	4600 W	5000 W
Maximum AC output power ($P_{ac,max}$ @cosφ=1)	4000 W ²⁾	4600 W	5000 W
Maximum apparent power (S_{max})	4000 VA ²⁾	4600 VA	5000 VA
Rated AC grid voltage (V_{acr})	230 V		
AC voltage range ²⁾	180...264 V		
Maximum AC output current ($I_{ac,max}$)	17.2 A	20.0 A	22.0 A
Contributory fault current	19.0 A	22.0 A	24.0 A
Rated output frequency (f) ³⁾	50/60 Hz		
Output frequency range ($f_{min} \dots f_{max}$) ³⁾	47...53/57...63 Hz		
Nominal power factor and adjustable range	> 0.995, adj. ± 0.1 - 1 (over/under excited)		
Total current harmonic distortion	< 3%		
AC connection type	Female connector from panel		
Output protection			
Anti-islanding protection	According to local standard		
Maximum external AC overcurrent protection	25.0 A	25.0 A	32.0 A
Output overvoltage protection - varistor	2 (L - N / L - PE)		
Operating performance			
Maximum efficiency (η_{max})	97.0%	97.0%	97.4%
Weighted efficiency (EURO/CEC)	96.5% / -	96.5% / -	97.0% / -
Feed in power threshold	8 W		
Night consumption	<0.4 W		

TECHNICAL DATA AND TYPES

Fimer Type code	UNO-DM-4.0-TL-PLUS-Q	UNO-DM-4.6-TL-PLUS-Q	UNO-DM-5.0-TL-PLUS-Q
Embedded communication			
Embedded communication interface 4)	Wireless		
Embedded communication protocol	ModBus TCP (SunSpec)		
Commissioning tool	Web User Interface, Aurora Manager Lite		
Monitoring	Plant Portfolio Manager, Plant Viewer, Plant Viewer for Mobile, Energy Viewer		
Optional board UNO-DM-COM kit			
Optional communication interface	RS485 (use with meter for dynamic feed-in control), Alarm/Load manager relay, Remote ON/OFF		
Optional communication protocol	ModBus RTU (SunSpec), Aurora Protocol		
Optional board UNO-DM-PLUS Ethernet COM kit			
Optional communication interface	Ethernet, RS485 (use with meter for dynamic feed-in control), Alarm/Load manager relay, Remote ON/OFF		
Optional communication protocol	ModBus TCP (SunSpec), ModBus RTU (SunSpec), Aurora Protocol		
Environmental			
Ambient temperature range	-25...+60°C /-13...140°F with derating above 50°C/122°F	-25...+60°C /-13...140°F with derating above 45°C/113°F 6)	-25...+60°C /-13...140°F with derating above 45°C/113°F
Relative humidity	0...100 % condensing		
Maximum operating altitude without derating	2000 m / 6560 ft		
Physical			
Environmental protection rating	IP 65		
Cooling	Natural		
Dimension (H x W x D)	553 x 418 x 175 mm / 21.8" x 16.5" x 6.9"		
Weight	15 kg / 33 lbs		
Mounting system	Wall bracket		
Safety			
Isolation level	transformerless		
Marking	CE , RCM		
Safety and EMC standard	IEC/EN 62109-1, IEC/EN 62109-2, AS/NZS 4777.2, EN 61000-6-1, EN 61000-6-2, EN 61000-6-3, EN 61000-6-4, EN 61000-3-11, EN 61000-3-12		
Grid standard (check your sales channel for availability) 5)	CEI 0-21, DIN V VDE V 0126-1-1, VDE-AR-N 4105, G83/2, G59/3, G98-1, G99-1, RD 413, ITC-BT-40, AS/NZS 4777.2, C10/11, IEC 61727, IEC 62116		
Available products variants			
Standard	UNO-DM-4.0-TL-PLUS-B-Q	UNO-DM-4.6-TL-PLUS-B-Q	UNO-DM-5.0-TL-PLUS-B-QU
With DC switch	UNO-DM-4.0-TL-PLUS-SB-Q	UNO-DM-4.0-TL-PLUS-SB-Q	UNO-DM-5.0-TL-PLUS-SB-QU

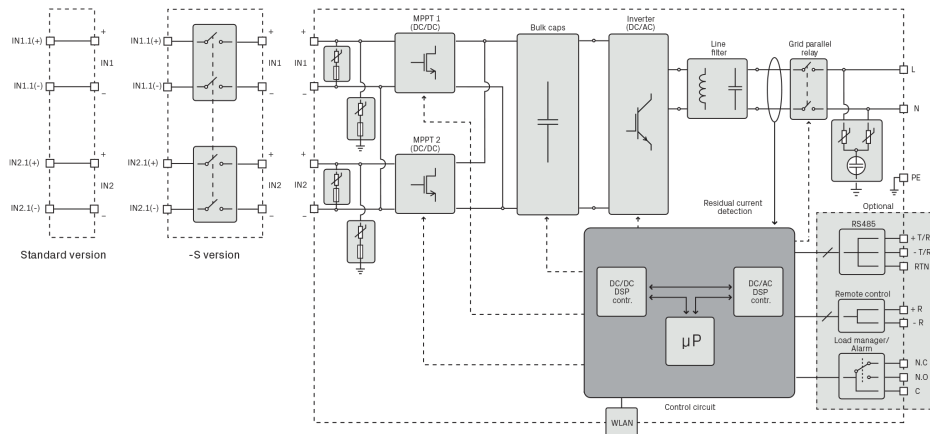

UNO-DM-4.0/4.6/5.0-TL-PLUS-Q string inverter block diagram

Models using other branded solar thermal or solar electric gear upon demand.